

Red Flash

Open-Area VADs



Product overview

Product Type	Visual Alarm Device
Part No.	55000-736APO XP95 Open-Area VAD Cat. W - Red Body (Red Flash) (W-2.4-6)
	55000-737APO XP95 Open-Area VAD Cat.W - White Body (Red Flash) (W-2.4-6)
Digital Communication	XP95, Discovery and CoreProtocol® compatible

Product information

The addressable Loop Powered Visual Alarm Devices (VADs) have been developed as primary or supplementary alarm devices. VADs may be used in situations where there is a risk that sounders will not be heard. It might also be required where deaf or hearing impaired persons may be present.

- Uses high intensity red LEDs
- EN 54-23 compliant Category W VAD
- Coverage W-2.4-6
- Flash rate 0.5 Hz
- Fault signal if LED check failed
- Locking mechanism (grub screw)
- Wide angle of visibility
- Synchronised flash rates with the Apollo Protocol

Manufacturer's Specification

All data is supplied subject to change without notice. Specifications are typical at 24 V, 25°C and 50% RH unless otherwise stated.

Coverage Class	W-2.4-6
Flash Colour	Red
Flash Rate	0.5 Hz
Digital Communications	XP95, Discovery and CoreProtocol compatible
Supply Voltage	17 V - 28 V dc (polarity sensitive)
Power Up Surge Current	1.5 mA
Quiescent	280 µA
Alarm Current (LED On)	16 mA
Operating temperature	-10 °C to +55 °C
Humidity (no condensation or icing)	0% to 95% RH
IP Rating	IP54 (when used with Part No. 45681-210, Part No. 45681-284 or Part No. SA5000-200 Mounting Base)
	IP55 (when used with the Deckhead Mounting Box Part No. 45681-217)
Approvals and Standards	EN 54-23
Dimensions	100 mm diameter x 50 mm height (58 mm height with XPERT 7 Mounting Base)
Weight	105 g
Material	White / Red fire retardant polycarbonate

Note: For Isolator data refer to Short-Circuit Isolation datasheet PP2090 available from www.apollo-fire.co.uk

Application

The Loop Powered Addressable Visual Alarm Device is a local area VAD designed for indoor use.

The VAD can be connected to systems with XP95, Discovery or Soteria® devices on the loop.

The Loop Powered VAD can be fitted to any XPERT 7 or XPERT 8 Mounting Base.

When fitted to an Ancillary Base Sounder (Part No. 45681-276) the sounder activation will be controlled by the VAD.

When fitted to an Integrated Base Sounder the devices can be controlled separately via their individual address.

Figure 1 shows the coverage volume for the ceiling category VAD with example calculations.

Figure 1: Category W Open-Area VAD with XPERT 7 Mounting Base coverage area

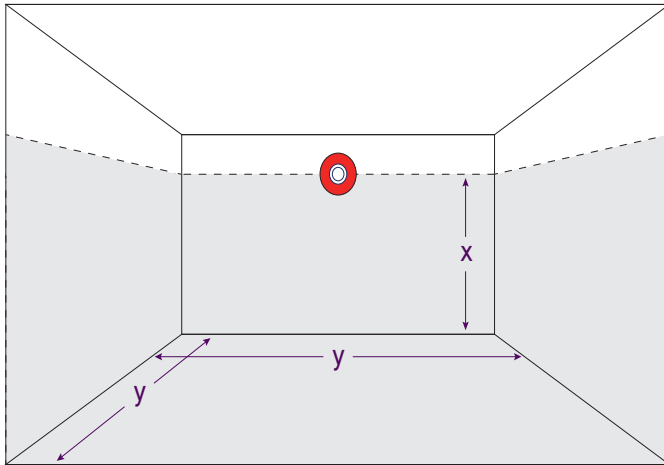

X - The maximum height of the device on the wall in meters with a maximum value of 2.4 m.
 Y - The width in meters of the square volume covered when the device is mounted to the wall at required height.

Part No. 55000-736 and 55000-737 (W-2.4-6) - coverage cuboid volume of 2.4 m x 6 m x 6 m = 86.4 m³

Table 1 Digital Communications Protocol Compatibility

Protocol	Device Behaviour
XP95 / Discovery †	XP95
CoreProtocol †	XP95

† Fire Control Panel Dependent

Electrical Considerations

The VAD is loop powered and requires no external power supply. It operates at 17 V - 28 V dc.

Addressing

The Loop Powered VAD must be assigned an address by coding the XPERT card.

Mechanical Construction

The case of the VAD is made of white or red self extinguishing polycarbonate with stainless steel contacts.

EMC Directive 2014/30/EU

The VAD complies with the essential requirements of the EMC Directive 2014/30/EU, provided that it is used as described in this datasheet.

A copy of the Declaration of Conformity is available from the Apollo website: www.apollo-fire.co.uk

Construction Products Regulation (EU) 305/2011

The VAD complies with the essential requirements of the Construction Products Regulation (EU) 305/2011.

A copy of the Declaration of Performance is available from Apollo website: www.apollo-fire.co.uk

Figure 2: Open-Area VAD (W-2.4-6) with XPERT 7 Mounting Base Dimensional Drawing

