

# Intelligent Visual Alarm Device



## Product Overview

<b>Product</b>	Intelligent Open-Area VAD Cat. W - White Body (White Flash) (W-3.1-10)
<b>Part No.</b>	SA5501-500
<b>Product</b>	Intelligent Open-Area VAD Cat. W - White Body (Red Flash) (W-3.1-9)
<b>Part No.</b>	SA5501-501
<b>Digital Communication</b>	CoreProtocol®, Discovery and XP95

## Product Information

The Intelligent Open-Area Visual Alarm Devices (VADs) have been developed as primary or supplementary alarm devices and can be connected to CoreProtocol, Discovery and XP95 systems.

VADs may be used in situations where there is a risk that sounders will not be heard, for example where there is high background noise such as in a workshop or machine room. They may also be required where deaf or hearing-impaired persons may be present. The Intelligent Open-Area VADs are approved EN 54-23 Cat W. devices in both the High and Low Power settings.

- EN 54-23 Compliant Category W VADs
- Built-in controllable isolator (when used with XPERT 8 Base)
- Configurable coverage volume, High and Low setting
- Available in Red or White Flash
- Wide angle of visibility
- Easy installation on Apollo XPERT 7 or 8 Base

## Manufacturer's Specification

All data is supplied subject to change without notice. Specifications are typical at 24V, 25°C and 50% RH unless otherwise stated.

Supply voltage	17V - 35V dc
Digital communication	CoreProtocol, Discovery and XP95
Quiescent current	1.2 mA
<b>Alarm current, LED on</b>	
High Coverage	14 mA
Low Coverage	9.5 mA
Flash rate	0.5 Hz
Operating temperature	-10 °C to +55°C
Storage temperature	-10 °C to +55°C
Humidity	0% to 95% RH (no condensation or icing)
IP Rating	IP21C
Standards	EN 54-23, EN 54-17
Dimensions	100 mm diameter x 40 mm deep
Weight	118 g
<b>Materials</b>	
Housing	White flame-retardant polycarbonate
Terminals	Tin-plated stainless steel

Note: For Isolator data refer to Short-Circuit Isolation data sheet PP2090 available from [www.apollo-fire.co.uk](http://www.apollo-fire.co.uk)

## Base compatibility

The Intelligent Open-Area VADs are compatible with the mounting bases and accessories (sold separately) that follow:

Part No. 45681-210APO	XPERT 7 Base
Part No. SA5000-200APO	XPERT 8 Base - White
Part No. 45681-797	BESA Adaptor Plate (Pack of 5)

Please note: To make use of the Short Circuit Isolator (SCI), the VAD must be installed on the SA5000-200/202 XPERT 8 Bases.

\*Note: Features are panel dependent. Please consult your panel manufacturer to confirm feature availability.

36 Brookside Road, Havant | Tel: +44 (0)23 9249 2412 | Email: [enquiries@apollo-fire.com](mailto:enquiries@apollo-fire.com)  
Hampshire, PO9 1JR, UK. | Fax: +44 (0)23 9249 2754 | Web: [www.apollo-fire.co.uk](http://www.apollo-fire.co.uk)

All information in this document is given in good faith but Apollo Fire Detectors Ltd cannot be held responsible for any omissions or errors. The company reserves the right to change the specifications of products at any time and without prior notice.



A Halma company

© Apollo Fire Detectors Ltd 2025



**Addressing**

The Open-Area Alarm Devices respond to their own individual address which is set via the appropriate XPERT address card Group address on CoreProtocol systems are set using the fire control panel.

Soft addressing is only available where supported by the fire control panel, in this instance no XPERT card should be fitted to the XPERT Base. Note - Hard addressing (using XPERT card) always takes priority over soft addressing.

The VAD coverage setting can be selected within the panel config. If being used in XP95 mode, follow the DIL switch Assignment guidance in the Installation Guide for VAD coverage settings, Volume and Tone selection, and Group Addressing.

**Application**

The base must be positioned on the wall, with the XPERT card pointing downwards for correct orientation and coverage, as per Figure 1.

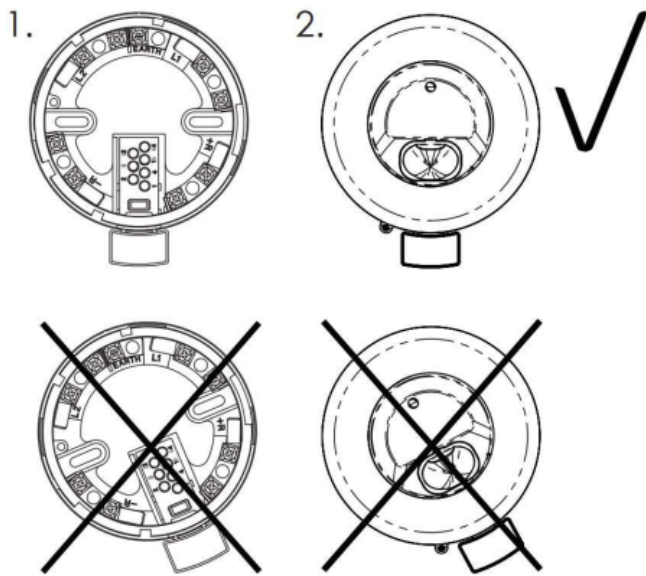

Figure 1

Accessory part 45681-797 can be used when mounting with BESA Boxes to ensure correct alignment.

Figure 2 shows the coverage volume for the wall category VAD with an example calculation.

H - The maximum height of the device on the wall in meters with a maximum value of 3.1 m.

W - The width in metres of the square volume covered when the device is mounted to the wall at required height.

Example - Part No. SA5501-500 (W-3.1-10) - coverage cuboid volume of 3.1 x 10 x 10 = 310 m<sup>3</sup>.

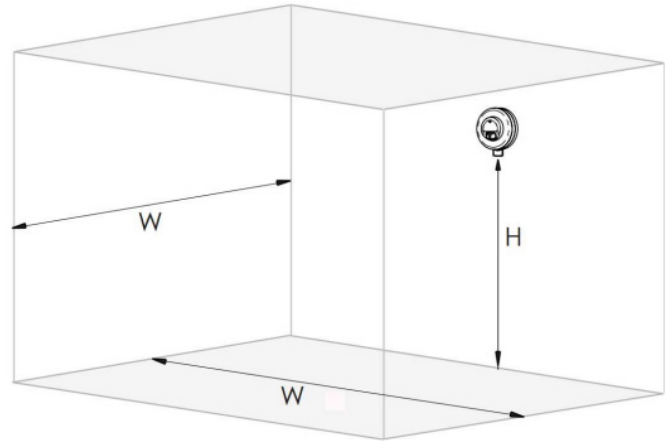

Figure 2

Device LED	VAD Coverage	
	High Current: 14mA	Low Current: 9.5mA
White Light Flash - SA5501-500	(W-3.1-10): Coverage cuboid volume of 3.1m x 10m x 10m = 310m <sup>3</sup>	(W-2.4-7.5): Coverage cuboid volume of 2.4m x 7.5m x 7.5m = 135m <sup>3</sup>
Red Light Flash - SA5501-501	(W-3.1-9): Coverage cuboid volume of 3.1m x 9m x 9m = 251.1m <sup>3</sup>	(W-2.4-7.5): Coverage cuboid volume of 2.4m x 7.5m x 7.5m = 135m <sup>3</sup>

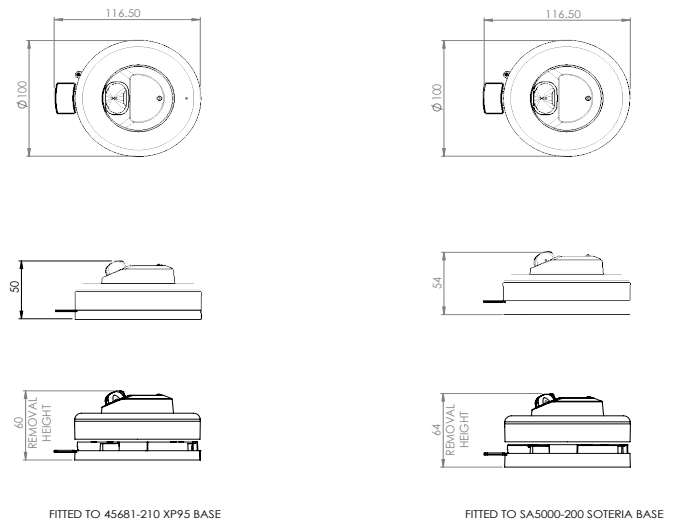

Figure 3

**EMC Directive 2014/30/EU**

The Intelligent Open-Area VAD complies with the essential requirements of the EMC Directive 2014/30/EU, provided that it is used as described in this data sheet.

A copy of the Declaration of Conformity is available from the Apollo website: [www.apollo-fire.co.uk](http://www.apollo-fire.co.uk)

Conformity of the Intelligent Open-Area VAD with the EMC Directive, does not confer compliance with the directive on any apparatus or systems connected to them.